



# Village of Roaming Shores

2500 Hayford Road  
P.O. Box 237  
Roaming Shores, Ohio 44084

440-563-3132, Administrator: 440-563-5083, Fax: 440-563-5912  
[www.roamingshoresOH.gov](http://www.roamingshoresOH.gov)

## Driveway / Yard Tile Permit

Application is for:     Driveway                       New  
                                  Yard Tile                          Repair / Replacement

Location: \_\_\_\_\_

Use (House, empty lot, etc...): \_\_\_\_\_

Owner: \_\_\_\_\_

Mailing address: \_\_\_\_\_

City/state/zip: \_\_\_\_\_

Daytime Phone: \_\_\_\_\_ Email: \_\_\_\_\_

I hereby request a  **driveway permit**  **yard tile permit** for the above location. I, or my representative, has obtained or will obtain the industry standard, applicable and compliant driveway pipe and/or yard tile.

Owner' signature: \_\_\_\_\_ Date: \_\_\_\_\_

Approved as follows: The pipe must be at a minimum double-walled, smooth inside, 30' in length and 12" in diameter.

Existing ditch grade:  OK     Flow line as set by Rome Rock Association     Other

Not approved    Reason: \_\_\_\_\_

By: \_\_\_\_\_ Date: \_\_\_\_\_

I hereby declare the installation has been completed according to the standards and requirements as set forth.

Name of contractor: **Rome Rock Association**

Pipe diameter: \_\_\_\_\_ Length: \_\_\_\_\_ Type: \_\_\_\_\_

Owner's signature: \_\_\_\_\_ Date: \_\_\_\_\_

Inspected by: \_\_\_\_\_ Date: \_\_\_\_\_

Comments: \_\_\_\_\_

John Ball, Mayor  
Leeann Moses, Clerk

Kevin Grippi, Administrator  
Robert Cook

Roy Brommer  
Cheryl Fain

Marlene Hocevar  
Edward Koziol

Mark Reighard, President  
Kyle Smith, Solicitor

**General Provisions In Force In So Far As They Apply To the Work To Be Done Under This Permit**  
(See Sect. 5547.04 Ohio Revised Code)  
General Provision Applicable to All Permits

The granting of this permit does not in any way abridge the right of the Rome Rock Association, Ashtabula County, Ohio in their jurisdiction over the RRA-owned roads. If, in the process of any future work or for the benefit of the traveling public, it becomes necessary, in the opinion of the Village of Roaming Shores, Ashtabula County, Ohio (Village) to order the removal, reconstruction, relocation, or repair shall be wholly at the expense of the owners thereof, and be made as direct by the Village.

The village administrator shall act for and in behalf of the Village in the issuance of and the carrying out of the provisions of all permits.

The administrator shall have full authority to insure the provisions of this permit are fully complied with; and retains the right to reject any materials or workmanship in the restoration of village roadway facilities. Failure on the part of the permittee to conform to the provisions of this permit will be cause for suspension, revocation and annulment of this permit as the village deems necessary.

If the party or parties to whom this permit is issued does anything contrary to the orders of the Village and after due notice, fails to correct such work or to remove such structure or material as he or they may be ordered to remove, the Village may, with or without notice, correct such work or remove such structures or material; and the party or parties to whom this permit is issued shall reimburse the Village for any expense incurred in correcting the work or removing the structure or materials.

All the work herein contemplated shall be done under the supervision and to the satisfaction of the Village, and the entire expense thereof, shall be borne by the party or parties to whom this permit is issued.

Except as herein authorized, no excavation shall be made or obstacle placed within the limits of the roadway in such manner as to interfere with travel over the road.

If any grading, sidewalk, or other work completed under this permit interferes with the drainage of the roads in any way, such catch basins and outlets shall be constructed as may be necessary to take proper care of said drainage.

The acceptance of this permit or the doing of any work thereunder shall constitute an agreement by the party or parties to whom the permit is granted to comply with all the conditions and restrictions printed or written herein.

All of the above conditions shall be applicable to the work herein authorized, unless the same are inconsistent with the conditions on the face of the permit, in which case the conditions written or printed on the face of the permit shall apply.

Roadway property, disturbed by the permittee, shall be restored using materials, design and workmanship in conformance with the Ashtabula County Commissioner's Highway Use Manual.

All pole lines are to be built in accordance with Administrative Order No. 72 of the Public Utilities Commission for Ohio.

All work requiring men or vehicles on the pavement or shoulders shall comply with all of the requirements of the Ohio Manual of Uniform Traffic Control Devices.

Failure to comply with this requirement will cause for immediate suspension of the permit until property traffic controls have been provided.

The permittee upon completion of the work shall leave the roadway clean of all rubbish, excess materials, temporary structures, and equipment, and all parts of the roadway shall be left in an acceptable condition.

The permittee shall save harmless the Village and all of its representatives from all suits, actions, or claims of any character, brought on account of any injuries or damages sustained by any person or property in consequence of any neglect or on account of any act or omission as a result of the issuance of this permit.

## NOTES AND INSTRUCTIONS

- 1) The pipe length shall be at least the driveway width plus 4 times the depth of the existing ditch. The minimum pipe length shall be 30 feet.
- 2) The depth of the existing ditch shall be defined as the vertical height as measured from the existing road berm to the bottom to the existing ditch.
- 3) The bedding shall be No. 8 stone, No. 6 stone, No. 411 stone, No. 504 stone, pea gravel, screened bankgravel (O.D.O.T. 410) or other material approved by the County Engineer.
- 4) The pipe material shall be galvanized corrugated steel (16 Ga. min.), reinforced concrete pipe, American standard steel pipe (3/8" min. wall thickness), Polyethylene double wall (smooth interior), Hancor HI-O, ADS N-12 or equal.
- 5) The amount of bedding required under a pipe larger than 18" in diameter must be determined on an individual basis, depending on site characteristics and on the pipe material being used. In no case shall the bedding be less than 4" thick for a pipe larger than 18" in diameter. Polyethylene pipe shall have granular bedding to 3/4 of its diameter in addition to the 2" below the pipe.
- 6) The flow line shall be established by the County Engineer or his representative.
- 7) The pipe diameter shall be determined by the County Engineer or his representative. The minimum pipe diameter shall be 12".
- 8) The pipe shall be backfilled with screened bankgravel (O.D.O.T. 410) or other material approved by the County Engineer.

NOTE: Tile for road frontage shall be installed according to tiled frontage requirements.

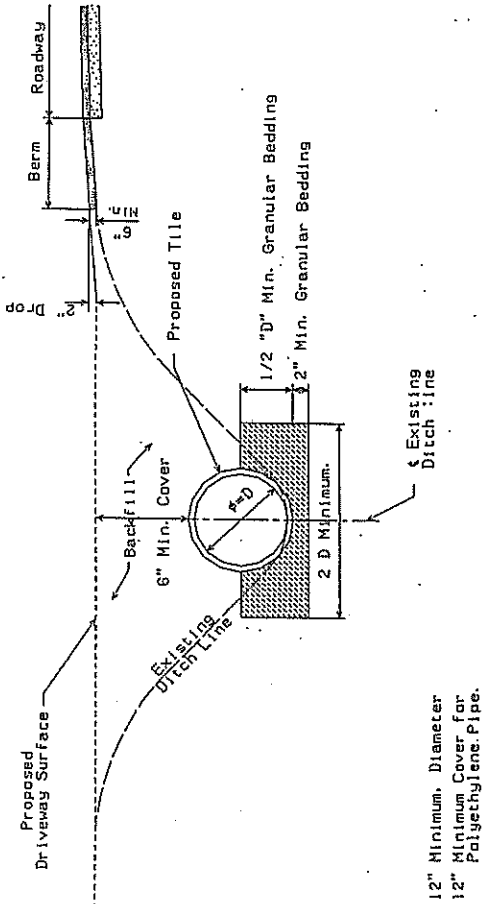

12" Minimum Diameter  
12" Minimum Cover for  
Polyethylene Pipe.

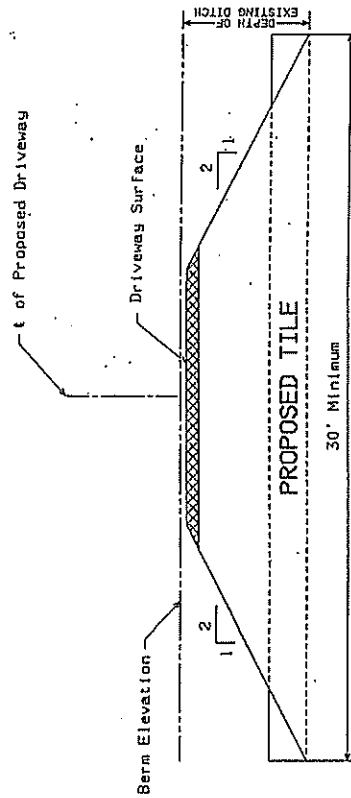

OHIO UTILITIES PROTECTION SERVICE  
**CALL**  
**BEFORE YOU DIG**  
 CALL 800-552-2764  
 OHIO UTILITIES PROTECTION SERVICE  
 "IT'S THE WAY"

ASHTABULA COUNTY  
**DRIVEWAY CULVERT STANDARD**

ASHTABULA COUNTY ENGINEER

DRAWN BY: \_\_\_\_\_ DATE: \_\_\_\_\_  
 REVISIONS: \_\_\_\_\_  
 DATE: \_\_\_\_\_